



## WRA\_N-2W & WRB\_N-2W Series

2W, WIDE INPUT, DUAL&SINGLE OUTPUT, DIP  
DC-DC CONVERTER

multi-country patent protection **RoHS**

### FEATURES

- Ultra Miniature Dip Package
- Wide (2:1) Input Range
- 1500VDC Isolation
- Operating Temperature: -40°C~+85°C
- No Heat Sink Required
- Short Circuit Protection (Automatic Recovery)
- RoHS Compliance

### APPLICATIONS

The WRB\_N-2W/WRA\_N-2W Series are specially designed for applications where a wide range input voltage power supplies are isolated from the input power supply in a distributed power supply system on a circuit board. These products apply to:

- 1) Where the voltage of the input power supply is wide range (voltage range: 2:1);
- 2) Where isolation is necessary between input and output(isolation voltage≤1500VDC);
- 3) Where the regulation of the output voltage and the output ripple noise are demanded.

### MODEL SELECTION

WRB2405N-2W

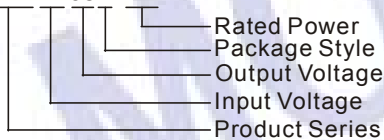

### MORNSUN America LLC

43 Broad Street  
Hudson, MA 01749  
Tel: 978-567-9610  
Fax: 978-567-9601  
<http://www.mornsunamerica.com>

### PRODUCT PROGRAM

Part Number	Input			Output			Efficiency (% Typ)
	Voltage (VDC)			Voltage (VDC)	Current (mA)		
	Nominal	Range	Max*		Max	Min	
WRA1205N-2W	12	9-18	22	±5	±200	±20	75
WRA1209N-2W				±9	±111	±11	76
WRA1212N-2W				±12	±83	±8	78
WRA1215N-2W				±15	±67	±7	77
WRB1203N-1W6				3.3	500	50	70
WRB1205N-2W				5	400	40	75
WRB1209N-2W				9	222	22	77
WRB1212N-2W				12	167	16	79
WRB1215N-2W				15	133	13	78
WRA2405N-2W				24	18-36	40	±5
WRA2409N-2W	±9	±111	±11				77
WRA2412N-2W	±12	±83	±8				78
WRA2415N-2W	±15	±67	±7				77
WRB2403N-1W6	3.3	500	50				72
WRB2405N-2W	5	400	40				76
WRB2409N-2W	9	222	22				78
WRB2412N-2W	12	167	16				80
WRB2415N-2W	15	133	13				80

\* Input voltage over it may cause permanent damage to the device.

Note: Operation under 10% load will not damage the converter; However, they may not meet all specification listed.

### OUTPUT SPECIFICATIONS

Item	Test conditions	Min	Typ	Max	Units
Voltage accuracy			±1	±3	%
Load regulation	From 10% to 100% load		±0.5	±1	
Line regulation	Input Voltage From Low to High		±0.2	±0.5	
Temperature drift	Refer to recommended circuit			±0.03	%/°C
Ripple&Noise*	20MHz bandwidth		35	100	mVp-p
Switching frequency	100% load, input voltage range		180~550(PFM)		KHz

\*test ripple and noise by "parallel cable" method. See detailed operation instructions at Testing of Power Converter section, application notes.

### ISOLATION SPECIFICATIONS

Item	Test conditions	Min	Typ	Max	Units
Isolation voltage	Flash tested for 60 seconds	1500			VDC
Isolation resistance	Test at 500VDC	1000			MΩ
Isolation Capacitance	Input/Output		85		pF

## COMMON SPECIFICATIONS

Item	Test Conditions	Min	Typ	Max	Units
Storage humidity				95	%
Operating temperature		-40		85	°C
Storage temperature		-50		125	
Lead temperature			15	35	
Temp. rise at full load	1.5mm from case for 10 seconds			300	
Cooling	Free air convection				
No-load Power			0.2		W
Short circuit protection	Short circuit protection	Continuous, Automatic			
Case material	Plastic(UL94-Vo)				
MTBF		1000			K Hours
Weigh			4.8		g

Note:

- All specifications measured at TA=25°C, humidity<75%, nominal input voltage and rated output load unless otherwise specified.
- See below recommended circuits for more details.

## TYPICAL CHARACTERISTICS

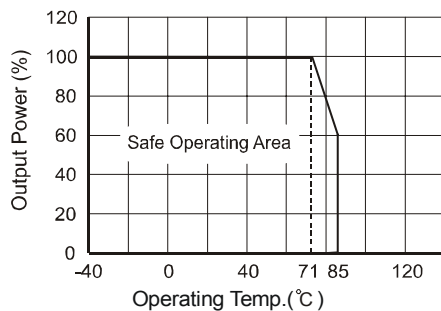

## OUTLINE DIMENSIONS & PIN CONNECTIONS

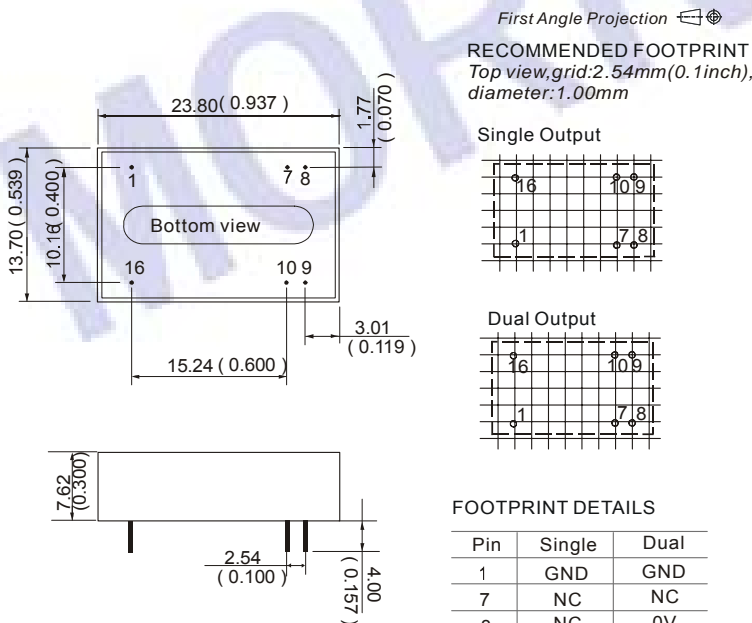

### FOOTPRINT DETAILS

Pin	Single	Dual
1	GND	GND
7	NC	NC
8	NC	0V
9	+Vo	+Vo
10	0V	-Vo
16	Vin	Vin

NC: No Connection

Note:

- Unit: mm(inch)
- Pin diameter: 0.50mm(0.020inch)
- Pin tolerances: ±0.05mm(±0.002inch)
- General tolerances: ±0.25mm(±0.010inch)

## APPLICATION NOTE

### Recommended Circuit

All the WRA\_N-2W & WRB\_N-2W Series have been tested according to the following recommended testing circuit before leaving factory(Figure 1). This series should be tested under load.

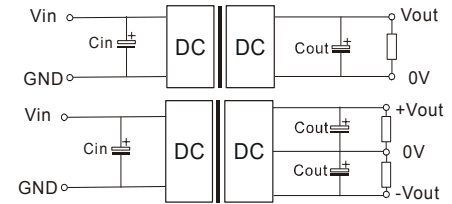

(Figure 1)

If you want to further decrease the input/output ripple, you can increase capacitance properly or choose capacitors with low ESR. However, the capacitance of the output filter capacitor must be proper. If the capacitance is too big, a startup problem might arise. For every channel of output, provided the safe and reliable operation is ensured, the greatest capacitance of its filter capacitor sees (Table 1).

External Capacitor Table (Table 1)

Vin (VDC)	Cin (uF)	Single Vout (VDC)	Cout (uF)	Dual Vout (VDC)	Cout (uF)
12	100	3.3	2200	±5	560
24	10-47	5	1000	±9	470
-	-	9	680	±12	330
-	-	12	470	±15	220
-	-	15	330	-	-

### Input Current

When it is used in unregulated power supply, be sure that the fluctuating range of the power supply and the rippled voltage do not exceed the module standard. Input current of power supply should afford the startup current of this kind of DC/DC module. (Figure 2),

Generally:  $I_p \leq 1.4 \cdot I_{n-max}$

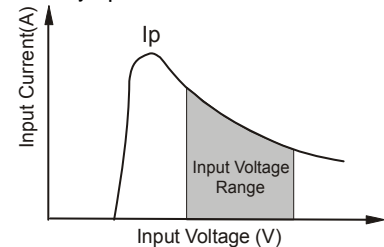

(Figure 2)

### Requirement on Output Load

To ensure this module operate efficiently and reliably, a minimum load is specified for this kind of DC/DC converter in addition to a maximum load (namely full load). During operation, make sure the specified range of input voltage is not exceeded, the minimum output load is not less than 10% Of the full load. If the actual load is less below the specified minimum load, the output ripple of this type of DC/DC converter may increase drastically. If the actual output power from the load in your circuit is very small, please connect a resistor with proper resistance at the output end to in parallel to increase the load, or use our company's other products with a lower rated output power.

**The products cannot be used in parallel and in plug and play.**