



multi-country patent protection **RoHS**

## K78XX-1000 Series

**WIDE INPUT NON-ISOLATED & REGULATED  
SINGLE POSITIVE /NEGATIVE OUTPUT**

### FEATURES

- Efficiency up to 96%
- Operating temperature: -40°C to +85°C
- Pin-out compatible with LM78XX Linear
- Short circuit protection, thermal Shutdown
- Low ripple and noise
- Microminiature SIP package
- No heat sink required
- Industry standard pinout
- MTBF>2,000,000 hours
- Can be used to convert a positive voltage into a negative voltage
- Only two extra capacitors are required
- Input voltage range can be lower than the output voltage for higher output voltages in negative application

### APPLICATIONS

The K78xx-1000 Series high efficiency switching regulators are ideally suited to replace 78xx linear regulators and are pin compatible. The efficiency of up to 96% means that very little energy is wasted as heat so there is no need for any heat sinks with their additional space and mounting costs.

### MODEL SELECTION

**K78XX-1000**

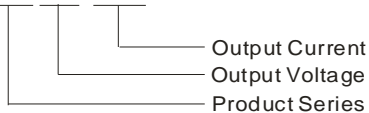

### MORNSUN America LLC

43 Broad Street  
Hudson, MA 01749  
Tel: 978-567-9610  
Fax: 978-567-9601  
<http://www.mornsunamerica.com>

### PRODUCT PROGRAM

Part Number	Input	Output		Efficiency(%)	
	Voltage Range (VDC)	Voltage (VDC)	Current (mA)	Vin (min.)	Vin(max.)
K7803-1000	4.75-28	3.3	1000	90	83
	4.75-25	-3.3	-600	80	82
K7805-1000	6.5-32	5.0	1000	93	88
	7.0-27	-5.0	-600	85	87
K78X6-1000	9.0-32	6.5	1000	94	90
	7.0-25	-6.5	-400	88	90
K7809-1000	12-32	9.0	1000	95	92
	7.0-23	-9.0	-400	89	91
K7812-1000	16-32	12	1000	96	94
	7.0-20	-12	-300	89	91

### OUTPUT SPECIFICATIONS

Item	Test conditions	Min	Typ	Max	Units
Output Voltage accuracy	100% full load		±2	±3	%
Line regulation	Vin=min. to max. at full load		±0.2	±0.4	
Load regulation	10% to 100% load		±0.4	±0.6	
Ripple+Noise*	20MHZ bandwidth		25	35	mVp-p
Short Circuit Input Power			0.5	1.8	w
Short circuit protection		Continuous, automatic recovery			
Thermal Shutdown	Internal IC junction		150		°C
Switching frequency	100% full load	280	330	450	KHz
Output Current Limit				2000	mA
Quiescent current	Positive Output		5	8	mA
	Negative Output		7	13	
Temperature coefficient	-40°C to +85 °C ambient			0.02	%/°C
Max capacitance load				1000	µF

\*Test ripple and noise by "parallel cable" method.

### COMMON SPECIFICATION

Item	Test conditions	Min	Typ	Max	Units
Operating Temperature		-40		85	°C
Operating Case temp.				100	
Storage Temperature		-55		125	
Lead Temperature	1.5mm from case for 10 seconds			300	
Cooling		Free Air Convection			
Case Material		Plastic (UL94-V0)			
Storage Humidity				95	%
MTBF		2000			K hours
Package Weight			3.7		g

Note:

1. All specifications measured at T<sub>A</sub>=25°C, humidity<75%, nominal input voltage and rated output load unless otherwise specified.
2. Only typical models listed. If you need other model, please confirm the power, input voltage and output voltage, then phone us.

## TYPICAL CHARECTERISTICS

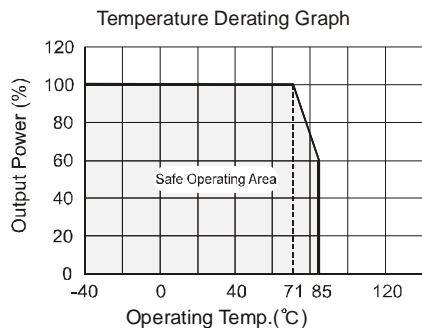

## EXTERNAL CAPACITOR TABLE

Part Number	C1,C3 (ceramic capacitor)	C2,C4 (ceramic capacitor)
K7803-1000	10uF/50V	22uF/6.3V
K7805-1000	10uF/50V	22uF/10V
K78X6-1000	10uF/50V	10uF/10V
K7809-1000	10uF/50V	10uF/16V
K7812-1000	10uF/50V	10uF/25V

## TYPICAL APPLICATION CIRCUIT

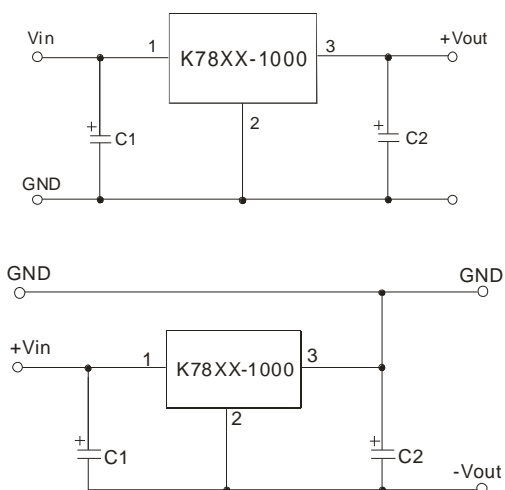

## APPLICATION EXAMPLE

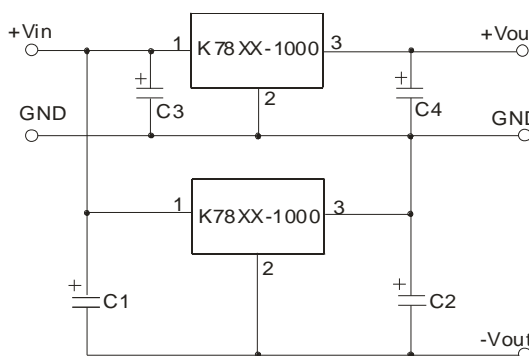

Note:

- 1.C1 and C2 are required and should be fitted close to the converter pins.
- 2.The capacitance of C1 ,C2,C3 and C4 sees external capacitor table,it can be increased properly if required, and tantalum or low ESR electrolytic capacitors may also suffice.
- 3.No parallel connection or plug and play.

## STANDARD APPLICATION CIRCUIT

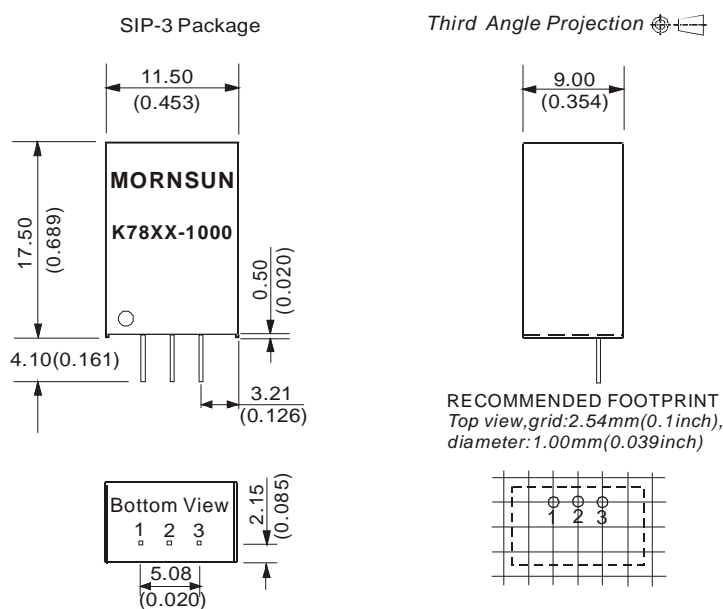

Note:  
Unit:mm(inch)  
Pin section:0.50\*0.30mm(0.020\*0.012inch)  
Pin tolerances:±0.10mm(±0.004inch)  
General tolerances:±0.25mm(±0.010inch)

### FOOTPRINT DETAILS

Pin	Positive	Negative
1	+Vin	+Vin
2	GND	-Vout
3	+Vout	GND

# CHARACTERISTICS(POSITIVE VOLTAGE OUTPUT)

## Efficiency

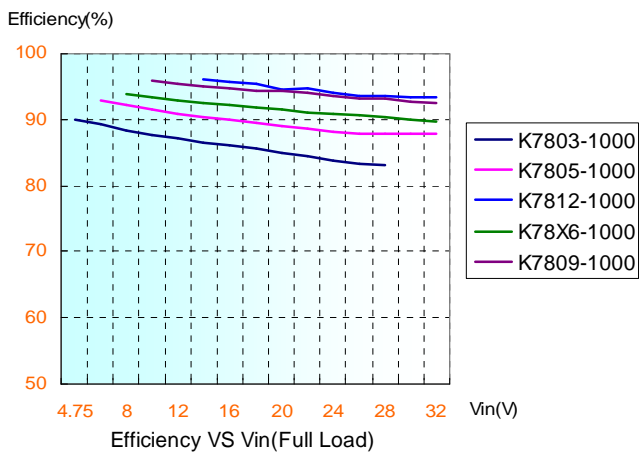

## Ripple

