

IE_KS-1W & IE_S-1W Series

1W FIXED INPUT ISOLATED & REGULATED DUAL OUTPUT DC-DC CONVERTER

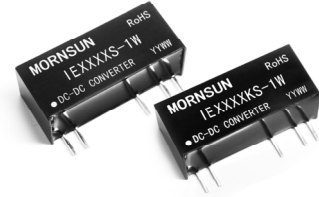

multi-country patent protection **RoHS**

FEATURES

- Low ripple and good EMC features
- Good dynamic feature
- 3KVDC Isolation
- SIP Package
- Temperature Range: -40°C to +85°C
- Internal SMD construction
- No Heatsink Required
- No External Component Required
- RoHS Compliance

APPLICATIONS

The IE_KS-1W&IE_S-1W Series are specially designed for applications where a group of polar power supplies are isolated from the input power supply in a distributed power supply system on a circuit board.

These products apply to:

- 1) Where the voltage of the input power supply is fixed (voltage variation $\leq \pm 5\%$);
- 2) Where isolation is necessary between input and output (isolation voltage $\leq 3000\text{VDC}$);
- 3) Where the regulation of the output voltage and the output ripple noise are demanded.

PRODUCT PROGRAM

Part Number	Input		Output			Efficiency (% Typ)
	Voltage (VDC)		Voltage (VDC)	Current (mA)		
	Nominal	Range		Max	Min	
IE0505S-1W	5	4.75-5.25	± 5	± 100	± 10	69
IE0505KS-1W*			± 5	± 100	± 10	54
IE0509KS-1W*			± 9	± 56	± 6	61
IE0512KS-1W			± 12	± 42	± 5	62
IE0515KS-1W			± 15	± 33	± 4	64
IE1205S-1W	12	11.4-12.6	± 5	± 100	± 10	72
IE1205KS-1W*			± 5	± 100	± 10	54
IE1209KS-1W*			± 9	± 56	± 6	61
IE1212KS-1W*			± 12	± 42	± 5	63
IE1215KS-1W*			± 15	± 33	± 4	64
IE2405S-1W	24	22.8-25.2	± 5	± 100	± 10	72
IE2405KS-1W			± 5	± 100	± 10	54
IE2409KS-1W*			± 9	± 56	± 6	60
IE2412KS-1W			± 12	± 42	± 5	63
IE2415KS-1W			± 15	± 33	± 4	64
* Designing.						

ISOLATION SPECIFICATIONS

Item	Test conditions	Min	Typ	Max	Units
Isolation voltage	Tested for 1 minute and 1 mA max	3000			VDC
Isolation resistance	Test at 500VDC	1000			MΩ

MODEL SELECTION

IE0505KS-1W

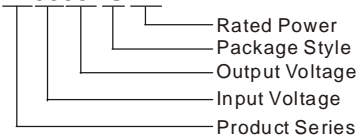

OUTPUT SPECIFICATIONS

Item	Test conditions	Min	Typ	Max	Units
Output power		0.1		1	W
Line regulation	For V_{in} change of $\pm 5\%$			± 0.25	%
Load regulation	10% to 100% full load			± 1	
Output voltage accuracy	100% full load			± 3	
Temperature drift	100% full load			0.03	$\%/^{\circ}\text{C}$
Output ripple*	20MHz Bandwidth		10	20	mVp-p
Output noise*	20MHz Bandwidth		50	100	
Switching frequency	Full load, nominal input		100		KHz

*Test ripple and noise by "parallel cable" method. See detailed operation instructions at testing of Power Converter section, application notes.

Note:

1. All specifications measured at $T_A=25^{\circ}\text{C}$, humidity<75%, nominal input voltage and rated output load unless otherwise specified.
2. See below recommended circuits for more details.

MORNSUN America LLC

43 Broad Street
Hudson, MA 01749
Tel: 978-567-9610
Fax: 978-567-9601
<http://www.mornsunamerica.com>

COMMON SPECIFICATIONS

Item	Test conditions	Min	Typ	Max	Units
Storage humidity				95	%
Operating temp. range		-40		85	°C
Storage temp. range		-55		125	
Temp. rise at full load			15	25	
Lead temperature	1.5mm from case for 10 seconds			300	
Cooling		Free air convection			
Case material		Plastic (UL94-V0)			
Short circuit protection	IEXXXXS-1W	Continuous			
	IEXXXXKS-1W *			1	s
MTBF		3500			K hours
Weight			5.2		g
*Supply voltage must be discontinued at the end of short circuit duration.					

TYPICAL CHARACTERISTICS

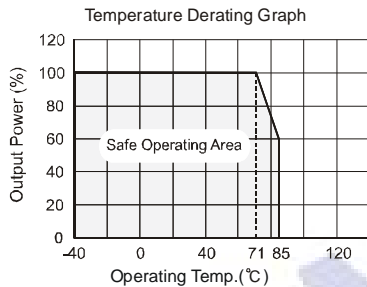

OUTLINE DIMENSIONS

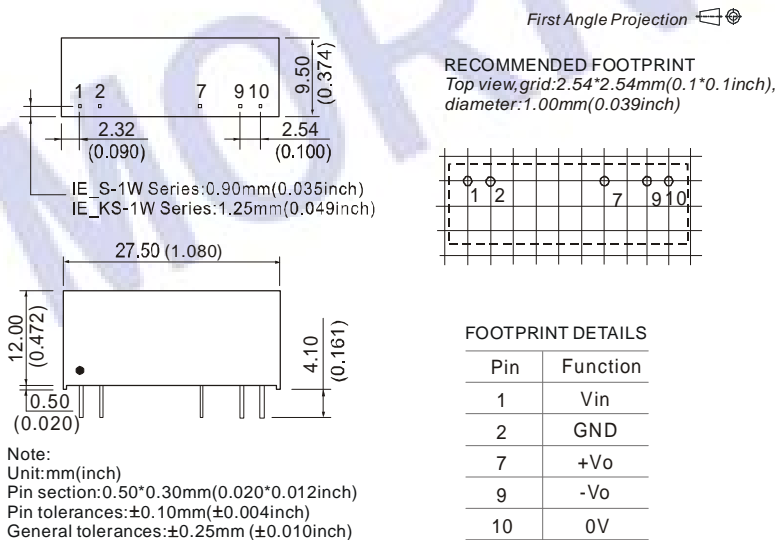

APPLICATION NOTE

Requirement on output load

To ensure this module can operate efficiently and reliably, a minimum load is specified for this kind of DC/DC converter in addition to a maximum load (namely full load). During operation, make sure the specified range of input voltage is not exceeded, the minimum output load is **not less than 10%** of the full load, that this product should never be operated under no load!

Filtering

To get an extreme low ripple, an "LC" filtering network may be connected to the input and output ends of the DC/DC converter, which may produce a more significant filtering effect. It should also be noted that the inductance and the frequency of the "LC" filtering network should be staggered with the DC/DC frequency to avoid mutual interference (see figure 1).

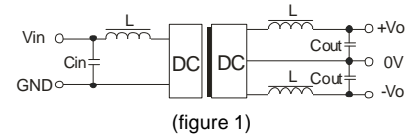

In some circuits which are sensitive to noise and ripple, a filtering capacitor may be added to the DC/DC output end and input end to reduce the noise and ripple. However, the capacitance of the output filter capacitor must proper. If the capacitance is too big, a startup problem might arise. For every channel of output, providing the safe and reliable operation is ensured, the greatest capacitance of its filter capacitor refer to the external capacitor table(table1).

EXTERNAL CAPACITOR TABLE (TABLE1)

Vin (VDC)	Cin (uF)	Vout (VDC)	Cout (uF)
5	4.7	±5	4.7
12	2.2	±9	2.2
24	1	±12	1
--	--	±15	0.47

Overload Protection

Under normal operating conditions, the output circuit of these products has no protection against over-current and short-circuits. The simplest method is to connect a self-recovery fuse in series at the input end or add a circuit breaker to the circuit.

When the environment temperature is higher than 71°C, the product output power should be less than 60% of the rated power.

No parallel connection or plug and play.